



Trout Talk

The Voice of the
Grand Rapids Steelheaders

ISSUE #416

MARCH 2009

PUBLISHER/EDITOR: DAVE NOWICKI

ASSISTANT EDITOR: GINNY NOWICKI

GRAND RAPIDS CHAPTER MEETING – MONDAY MARCH 30, 2009 – 7:30 PM
SOCIAL HOUR 6:30 – 7:30 PM

33RD ANNUAL MEMBERSHIP MEETING PROGRAM

KELLEY SMITH
FISHERIES CHIEF MICHIGAN DNR

KELLEY SMITH FROM THE MICHIGAN DNR WILL PRESENT A PROGRAM ON THE CURRENT ISSUES FACING THE STATE IN FISHERIES. A QUESTION AND ANSWER SESSION WILL FOLLOW THE PRESENTATION. 2009 FISHING AND HUNTING LICENSES WILL BE ON SALE AT THIS MEETING—PROVIDED BY AL & BOB'S SPORTS. ALL THE FINAL DRAWINGS FROM THE SPORT SHOW WILL ALSO TAKE PLACE. SOCIAL HOUR IS FROM 6:30 PM TO 7:30 PM WITH REFRESHMENTS AND LITE LUNCH. THE MEETING BEGINS AT 7:30 PM. BRING YOUR USED OR NEW FISHING TACKLE THAT YOU DON'T NEED TO SELL AT THE SWAP TABLE. *BRING YOUR FAMILY, FISHING BUDDIES, SIGN UP A NEW MEMBER. SEE YOU ON MONDAY MARCH 30, 2009.*

NOTE:

IF YOU NEED A MEMBERSHIP CARD, ATTEND A MEMBERSHIP MEETING OR SEND A SELF ADDRESSED STAMPED ENVELOPE TO THE CHAPTER POST OFFICE BOX LISTED IN THIS ISSUE.
IF YOUR MEMBERSHIP IS UP TO DATE YOUR CARD WILL BE SENT TO YOU.

CHAPTER OFFICERS

PRESIDENT -----DAVE NOWICKI -----616-532-7727
VICE PRESIDENT-----STEVE HEINTZELMAN-616-791-7009
V.P./TREASURER ---- BOB STREK-----616-453-3109
SECRETARY -----VIKKI GUILS-----616-677-3442

DIRECTORS

BOB ANTZAK ----- YR.FISH CONTEST---616-895-6874
AL DAVIS-----SMALL FRY CONTEST-616-363-3564
RENEE DAVIS-----MEMBER BENEFITS---616-363-3564
CHRIS EDWARDS-----PROGRAMS-----616-863-6943
DICK GROMKO ----- MEETING PREP.-----616-455-1336
KRIS GUILS-----MUCC,GRANTS-----616-677-3442
BILL NEWELL-----RAFFLES-----616-897-6949
BUD POTTS-----SALMON IN SCHOOLS---616-453-5812

ALTERNATE DIRECTORS

JIM LARSEN-----MEMBERSHIP-----616-453-4779
IRV BYRBE-----RAFFLES-----616-678-4780
JOHN GARDNER-----RIVER CONTESTS-----616-304-3529
BRIAN BOOMSMA-----RAFFLES-----616-538-4494
JOHN STAUFFER-----CLOTHING-----616-453-1327
DAVE ANDERSON-----PROGRAMS-----616-450-3577

SPECIAL CHAPTER FUNCTIONS

FISHING PARTNERS-----JIM LARSEN-----616-453-4779
MEMBER BENEFITS-----RENEE DAVIS-----616-363-3564
NEWSLETTER-----DAVE NOWICKI-----616-532-7727
PAST PRESIDENT-----TONY NIKODEMSKI---616-363-7833
SPRING SHOW-----DAVE NOWICKI-----616-532-7727
STATE DIR.-----RENEE DAVIS-----616-363-3564

GRAND RAPIDS STEELHEADERS FOUNDATION

PRESIDENT/MARKETING-NORM VANSICKLE-----616-532-5845
V.P./SEC/TREASURE---VIKKI GUILS-----616-677-3442
DIRECTOR-----TOM BEREZA-----616-784-0490
DIRECTOR-----MARTIN KUKS-----616-784-3068
DIRECTOR-----HENRY ZEMAN-----616-453-1554

CHAPTER MEETINGS

MEMBERSHIP MEETINGS ARE HELD ON THE LAST MONDAY OF THE MONTH, AUGUST THRU JUNE. SOCIAL HOUR 6:30-7:30 PM. THE MEETING STARTS AT 7:30 PM. BOARD OF DIRECTORS MEETINGS ARE HELD THE FIRST MONDAY OF EACH MONTH AT 7:30 PM. MEMBER CONCERNS SHOULD BE DIRECTED TO A BOARD MEMBER FOR DISCUSSION AT A BOARD MEETING. BOARD MEETINGS ARE OPEN TO ALL MEMBERS. ALL MEETINGS ARE HELD AT DIAMOND AVENUE HALL, 435 DIAMOND AVENUE N.E. DIAMOND AVENUE IS THREE BLOCKS WEST OF FULLER AVENUE, OFF MICHIGAN STREET. GO NORTH ON DIAMOND ONE BLOCK.

EDITORS NOTE

IF YOU HAVE INFORMATION THAT YOU WOULD LIKE PUBLISHED IN THE "TROUT TALK", SEND IT TO US BY THE FIRST MONDAY OF THE MONTH THAT YOU WOULD LIKE IT PUBLISHED. SEND YOUR INFORMATION TO DAVE NOWICKI, 2471 ANCIENT S.W., WYOMING, MICHIGAN, 49519 OR CALL 616-532-7727, OR E-MAIL polander@hotmail.com

THIS NEWSLETTER IS THE OFFICIAL PUBLICATION OF THE GRAND RAPIDS CHAPTER OF THE MICHIGAN STEELHEAD AND SALMON FISHERMAN'S ASSOCIATION. THIS NEWSLETTER IS PUBLISHED EACH MONTH AND IS PROVIDED FREE TO ALL CURRENT MEMBERS OF THE GRAND RAPIDS CHAPTER. ADVERTISEMENTS FOR TRAVEL, INSURANCE & CREDIT CARD (FINANCIAL) AGENCIES ARE NOT ALLOWED IN THIS NEWSLETTER. ALL CONTENTS OF THIS NEWSLETTER ARE COPYRIGHT BY THE GRAND RAPIDS CHAPTER. PERMISSION IS GRANTED TO ALL MSSFA CHAPTERS FOR THE USE OF ALL EDITORIAL MATERIALS CONTAINED IN THIS PUBLICATION. ALL GRAPHIC AND PHOTOGRAPHIC IMAGES ARE SUBJECT TO THE RIGHTS OF THE ARTIST OR PHOTOGRAPHER.

ATTENTION

CHECK THE FIRST LINE OF YOUR ADDRESS LABEL ON THIS NEWSLETTER. IF IT IS DATED BEFORE THIS MONTH AND YEAR, YOUR MEMBERSHIP HAS EXPIRED. IF YOUR MEMBERSHIP HAS EXPIRED, YOU ARE NO LONGER AN ACTIVE MEMBER, AND CANNOT PARTICIPATE IN CHAPTER EVENTS THAT REQUIRE ACTIVE MEMBERSHIP. PLEASE USE THE MEMBERSHIP APPLICATION BELOW TO RENEW YOUR MEMBERSHIP. IF YOU DON'T NEED TO USE THE APPLICATION AT THIS TIME, MAYBE A FISHING BUDDY OF YOURS CAN. REMEMBER THERE IS STRENGTH IN NUMBERS.

MEMBERSHIP APPLICATION

MICHIGAN STEELHEADERS
GRAND RAPIDS CHAPTER
P.O. BOX 1474
GRAND RAPIDS, MI. 49501

NAME _____ DATE _____

ADDRESS _____

CITY, STATE _____

ZIP CODE _____ AMOUNT \$30.00

PHONE _____ AREA CODE _____

NEW MEMBER RENEWAL
\$30.00 \$30.00

SENIOR RENEWAL NEW SENIOR
\$20.00 \$30.00

REFERRED BY _____

YOUR BUSINESS

COULD BE ADVERTISING IN THIS FISHERPERSONS/BOATERS NEWSLETTER FOR THE FOLLOWING RATES:

BUSINESS CARD - \$8/MONTH \$80/YEAR
¼ PAGE - \$15/MONTH \$150/YEAR
½ PAGE - \$20/MONTH \$200/YEAR
FULL PAGE - \$35/MONTH \$350/YEAR

WE PUBLISH 11 ISSUES EACH YEAR

FOR MORE INFORMATION ON ADVERTISING, PLEASE CONTACT:

DAVE NOWICKI
2471 ANCIENT S.W.
WYOMING, MI. 49519
PHONE: 616-532-7727

E-MAIL: polander@hotmail.com

VISIT US AT: mssfa.com GRAND RAPIDS CHAPTER

WELCOME NEW MEMBERS

THE GRAND RAPIDS CHAPTER WELCOMES THE FOLLOWING NEW AND RENEWING MEMBERS.

DAVID EDEL	MIKE HERRICK	SKIP GILMORE
HENRY SLUIS III	ANDRIS SALKA	TOM KRZCIOK
DAVID LEE GROENDYKE	HENRY ZEMAN	TOM WHITE
ART SCHOTTS	KEN HUTCHENS	PAUL WEIKERT
MARK VEURINK	DANA BONNEY	

THE FOLLOWING MEMBERSHIPS EXPIRED IN DECEMBER 2008:

JOHN BALL DAVID ELLIOTT

THE FOLLOWING MEMBERSHIPS EXPIRED IN JANUARY 2009:

ROBERT CUNNINGHAM

THE FOLLOWING MEMBERSHIPS EXPIRED IN FEBRUARY 2009:

STEVE DENNIS	MIKE GROMKO	MATT WING
PAUL SKRZYCKI		

THE FOLLOWING MEMBERSHIPS EXPIRE THIS MONTH:

SHANE ADAMS	PAUL ADAMS	MARK DODGE
BLAINE GORBY	STEVE HEINTZELMAN	JOHN KNENZER
STEVE LEBLANC	GARY MOORE	GARY PERDEW
CHRIS PRANOMVANAUECH	RONALD SCHWAB	
ROBERTA TAYLOR	GUY WATROUS	

THE FOLLOWING MEMBERSHIPS EXPIRE IN APRIL 2009:

KEN AMID	DAVID ANDERSON	ED ANDERSON
WILLIAM BALE	DOUG BARTON	RALPH BELL
ROGER BELTER	GORDON BERNHARDT	ROBERT BLOOM
RYAN BOLUYT	EDWARD BOONE	GARY BOWMAN
GUY BRANDT	WM. BRINKMAN	BOB BROMLEY
JEFFERY BUSTOS	MONTY BYINGTON	KEVIN CHOPP
JIM CLAW	JOHN CRAMBLET	AL DAVIS
JASON CUNNINGHAM	SCOTT DEGRAAF	JAMIE DOWNS
DAVID ENGEL	ENRIQUE FALLS	THOMAS FOX
DAVID GRIFFIN	KRIS GUILLES	TOM HAMILTON
TERRY GULLIFORD	TIM HEIDEMA	LES HENDERSON
AMY HEINTZELMAN	LARRY HITSMAN	JEFF KEIZER
KENNETH HOLIFIELD	RICHARD KENNEDY	PAUL KIK
WILLIS KERRIDGE	MARK KINSLER	CHIP KLEIN
MARTIN KUKS	JAMES LARSEN	ROGER MADSEN
SEBASTEAN MALARZ	SCOTT MAYNARD	HAROLD MERZ
SUE MERDZINSKI	HOWARD MIDDAUCH	BILL NEWELL
TODD NEEDHAM	ROBERT MORELAND	GENE PALMER
GEORGE PALMER	JEREMIAH PARKS	BILL PATTEUW
BRETT PAYNE	DANIEL RIGHTMIRE	STEVE ROMSEK
TODD RONDA	MATT SCHALK	ART SCHULTZ
NICK SCHWARTZ	DAWN SCOTT	DAVID SCRIPPS
GORDY SIBCE	KEITH SOVA	ED SUBLER
JOHN STAUFFER	CHARLES TENBRINK	RYAN TIMMER
ROB URGNEY	MARK VENEMA	
ROBERT WINKELS		

**IF YOU DO NOT RENEW YOUR
MEMBERSHIP YOU
WILL NOT RECEIVE A MONTHLY
NEWSLETTER! RENEW YOUR MEMBERSHIP
ON TIME!**

PASSING ALONG INFORMATION

The Officers of the Grand Rapids Steelheaders would like to pass to its member's information that we receive from the State Organization, DNR as well as other sources pertaining to the water ways in and around the State of Michigan. If you would like to receive this information send Bob Strek an email at rstrek@aol.com requesting to receive this information, if you signed up at a Membership meeting you are on the list.

GREAT LAKES ANGLER MAGAZINE

SPECIAL

ORDER THE GLA MAGAZINE NOW AND GET NINE BIG ISSUES OF TIMELY ANGLING OPPORTUNITIES AND COLORFUL GREAT LAKES FEATURES FOR ONLY \$13. SAVE EVEN MORE ON TWO AND THREE YEAR SUBSCRIPTIONS FOR \$25 OR \$35 RESPECTIVELY! JUST CALL 800-214-5558 AND MENTION CODE "ZMSHC8". OFFER VALID FOR MICHIGAN STEELHEADERS ONLY.

GRI
GRAND
RIVER
INTERIORS

GRAND RIVER INTERIORS INC.
974 Front Ave. NW • Grand Rapids, MI 49504
(616) 454-3258 • FAX (616) 454-1502
mail@grandriverinteriors.com
www.grandriverinteriors.com



S.K. ENTERPRISES, INC.
PET SUPPLIES
"PLUS"
DISCOUNT PET FOODS & SUPPLIES

2033 28th St., SW
Wyoming, MI 49509

Phone (616) 532-5171
Fax (616) 530-6710

BOARD OF DIRECTORS MEETING MINUTES OF MARCH 2, 2009

BOARD MEMBERS PRESENT: STEVE HEINTZELMAN, BOB STREK, VIKKI GUILLES, RENEE DAVIS, AL DAVIS, DICK GROMKO, JIM LARSEN, IRV BYXBE, BRIAN BOOMSMA, JOHN STAUFFER, DAVE ANDERSON, BILL NEWELL, BUD POTTS, TONY NIKODEMSKI.
ABSENT EXCUSED DAVE NOWICKI, BOB ANTZAK, RENEE DAVIS, CHRIS EDWARDS, KRIS GUILLES, MEMBERS PRESENT NORM VAN SICKLE, AMY HEINTZELMAN., RON LARSEN.

1. BOB STREK CALLED THE MEETING TO ORDER AT 7:30 P.M.
2. A MOTION WAS MADE TO ACCEPT THE SECRETARY'S REPORT AS PRINTED IN THE NEWSLETTER.
3. BOB STREK GAVE THE TREASURER'S REPORT AND ENCOURAGED TICKET SALES.
4. DICK GROMKO IS GREAT WITH MEETING PREP.
5. STEVE HEINTZELMAN AND BOB STREK RECEIVED DONATIONS FROM AL & BOB'S SPORTS TO GEY US THRU THE SPORT SHOW.
6. GRAND HAVEN IS LOOKING FOR HELP AT THE NET PEN OPERATION. VOLUNTEERS ARE NEEDED ON MARCH 14 AND 28. CONTACT BOB STREK FOR DETAILS.
7. JIM LARSEN COVERED MEMBERSHIP.
8. BUD POTTS COVERED THE SALMON IN SCHOOLS, FEEDERS NEED UPDATING. 2 SCHOOLS HAVE REQUESTED TO BE ADDED.
9. TEXAS HOLD'EM IS SET FOR 4 TIMES THIS YEAR. FIRST TIME IS IN APRIL.
10. THANK YOU TO BOB SCHULTZ FOR THE CONTRIBUTION OF SALE OF A USED VEHICLE SALE.
11. CLOTHING SALES ARE DOING WELL. WE HAVE SOLD MOST INVENTORY.
12. THE TACKLE SALE IS SET FOR SATURDAY MARCH 7. SOME CONFLICTS WITH OTHER GROUPS, BUT TURN OUT WILL BE GOOD.
13. WENDY OLGIVIE CAME TO THE LAST MEMBERSHIP MEETING. BOB STREK TALKED ABOUT HIS INSITE ON THE PROJECT, AS DID BUD POTTS.
14. BILL NEWELL WILL BE RUNNING THE SPRING RIVER CONTEST ON MARCH 28.
15. BOB STREK WENT THRU THE SPORT SHOW LINE UP.
16. A DISCUSSION WAS HELD TO HELP WITH COSTS. MEMBERSHIP DRAWING WILL BE CHANGED TO WHERE ALL TICKETS (TICKET PER HOUR WORKED) AND ON SUNDAY ALL TICKETS WILL GO INTO A HOPPER AND 4 TICKETS WILL BE DRAWN ON SUNDAY.
17. THE SPRING AND FALL RIVER CONTEST FEE HAS BEEN RAISED TO \$5.00.
18. THE MEETING ADJOURNED AT 9:20.

VIKKI GUILLES, SECRETARY

MEMBERSHIP MEETING MINUTES OF FEBRUARY 23, 2009

1. BOB STREK CALLED THE MEETING TO ORDER AT 7:30 P.M.
2. VIKKI GUILLES READ THE MINUTES AND THEY WERE ACCEPTED AS READ.
3. BOB STREK GAVE THE TREASURER'S REPORT AND IT WAS ACCEPTED AS READ.
4. NEW MEMBERS AND GUESTS WERE WELCOMED.
5. KRIS GUILLES GAVE A REPORT ON THE ICE FISHING OUTING.
6. FISHING REPORTS WERE SHARED.
7. THE SPRING RIVER CONTEST WILL BE HELD ON MARCH 28. SEE BILL NEWELL OR BOB STREK TO SIGN UP.
8. FISHING HATS WERE GIVEN TO CHILDREN 15 AND UNDER.
9. BOB STREK, BUD POTTS, GAVE A REPORT ON THE SALMON IN SCHOOLS PROJECT.
10. THE TACKLE SALE IS SET FOR MARCH 7 AT DIAMOND HALL.
11. VIKKI GUILLES GAVE AN OVERVIEW OF FOUNDATION EVENTS.
12. BOB STREK GAVE AN OVERVIEW OF THE SPORT SHOW. SPORT SHOW CAPTAINS WERE ASKED FOR STATUS. NEW WORKER SIGN UPS WERE REQUESTED. TICKET SALES WERE ENCOURAGED.
13. BRIAN MULLEN TALKED ABOUT BASIC BOAT MAINTENANCE AND WINTERIZATION.
14. WENDY OLGIVIE GAVE A PRESENTATION ON THE RIVER AND TOOK QUESTIONS.
15. VOTING WAS HELD.
16. THE MEMBERSHIP DRAWING WAS HELD AND THE WINNER WAS SKIP GILMORE.
17. THE TACKLE AND 50/50 DRAWINGS WERE HELD.
18. THE MEETING ADJOURNED AT 9:15.

VIKKI GUILLES, SECRETARY

THE YEAR LONG SMALL FRY FISHING CONTEST

FOR ALL BOYS AND GIRLS UP TO 15 YEARS OLD WHO'S PARENTS/RELATIVES/GUARDIANS ARE SIGNED UP WITH BOB ANTZAK IN THE YEAR LONG FISHING CONTEST. THESE SMALL FRY'S ARE ELIGIBLE TO ENTER FISH OF ALL SPECIES CAUGHT ON THE BIG LAKE, INLAND LAKES, AND ANY RIVERS.

RULES ARE:

- 1) PARENTS/RELATIVES/GUARDIANS MUST BE SIGNED UP IN THE YEAR LONG BIG LAKE AND RIVER CONTEST WITH BOB ANTZAK. CALL BOB TO ENTER AT 616-895-6874 OR SEE HIM AT THE MEMBERSHIP MEETINGS. THE CONTEST RUNS FROM DECEMBER 1, CURRENT YEAR TO NOVEMBER 30 FOLLOWING YEAR. COST IS \$5.00 PER FAMILY.
- 2) ALL FISH CAUGHT MUST BE WEIGHTED TO ENTER. ANY SPECIES OF FISH CAUGHT CAN BE ENTERED.
- 3) ON A POSTCARD OR CARD PLEASE TELL US WHEN AND WHERE THE FISH WAS CAUGHT, INCLUDE PHOTO IF YOU HAVE ONE, AND MOST IMPORTANT HOW MUCH IT WEIGHED. PARENTS/RELATIVES/GUARDIANS MUST SIGN POST CARD OR CARD.
- 4) ALL SMALL FRY ENTRY'S NAMES WILL BE POSTED IN THE TROUT TALK NEWSLETTER EACH MONTH.
- 5) PRIZE TROPHY'S FOR THE LARGEST FISH AND 2ND PLACE LARGEST FISH IN ALL CATEGORIES WINS TROPHY AT THE JANUARY MEMBERSHIP MEETING. ALL ENTRIES, WIN OR LOSE WILL RECEIVE A PARTICIPANT RIBBON. PHOTOS ARE AN OPTION BUT I HEARD TO TELL THE EDITOR OF TROUT TALK SAYS DON'T BE SURPRISED IF YOU SEE YOUR PICTURE IN THE NEXT ISSUE OF TROUT TALK WITH YOUR CATCH.

- 6) SEND ALL ENTRIES AND PHOTOS TO

AL DAVIS
1950 GRAND RIVER DRIVE
ADA, MI. 49301
616-363-3564

- 7) THE 2009 CONTEST BEGINS DECEMBER 1, 2008 AND ENDS ON NOVEMBER 30, 2009.

2009 SMALL FRY CONTEST ENTRIES

PERCH -- ZACK STREK



PERCH FISHING WITH
ZACK STREK



FISHING PARTNERS

THE CHAPTER HAS AS FISHING PARTNERS PROGRAM, TO GET MEMBERS TO FISH WITH OTHER MEMBERS, AND TO HELP NEW MEMBERS GET INVOLVED WITH THE CHAPTER. TO GET STARTED IN THE PROGRAM WE NEED YOUR NAME, ADDRESS, PHONE NUMBER AND THE TIMES THAT YOU ARE AVAILABLE TO FISH. DO YOU HAVE A BOAT? NEED A PARTNER FOR THE RIVER, LAKE, ETC, NEED A CREW MEMBER FOR YOUR BOAT, NEED A MEMBER TO FISH A CHAPTER OUTING, TEACH NEW MEMBERS HOW TO CATCH STEELHEAD AND SALMON, ABLE TO TAKE OTHER MEMBERS OUT FISHING. CONTACT JIM LARSEN AT 616-453-4779. JIM WILL PUT MEMBERS TOGETHER SO THEY CAN LEARN NEW TECHNIQUES AND MEET OTHER CHAPTER MEMBERS. IF YOU HAVE ANY QUESTIONS CONTACT JIM AT THE ABOVE PHONE NUMBER.

FREE MEMBERSHIPS

THE FOLLOWING MEMBERS HAVE WON FREE MEMBERSHIPS IN THE PAST YEAR BY ATTENDING MEMBERSHIP MEETINGS OR WORKING AT THE SPORT SHOW.

JANUARY 2009	PRESTON KUKS
FEBRUARY 2009	SKIP GILMORE
SPORT SHOW 2008	BRIAN BOOMSMA, EGON KELTING, GENE PALMER, SUE EDWARDS, JIM LARSEN, BUD POTTS, SUZI MERDZINSKI, JOHN GARDNER, SALLY WILSON, BILL RATLIFF, PRESTON KUKS, RENEE DAVIS.
MARCH 2008	BOB MCCRACKEN
APRIL 2008	VIKKI GUILLES
MAY 2008	BILL NEWELL
JUNE 2008	MICHAEL BOLHOUSE
AUGUST 2008	BOB FIEBIG
SEPTEMBER 2008	DAVE VAN MALE
OCTOBER 2008	LARRY MAREK
NOVEMBER 2008	IRV BYXBE

ATTEND THE MEMBERSHIP MEETINGS, INCREASE YOUR CHANCE TO WIN A MEMBERSHIP.

CHAPTER CLOTHING

THE CHAPTER NOW HAS CHAPTER SHIRTS, CAPS, ETC. FOR SALE. IF YOU WOULD LIKE TO PURCHASE SOME CHAPTER CLOTHING CONTACT JOHN STAUFFER AT 616-453-1327 OR VIKKI GUILLES AT 616-677-3442. THEY CAN GIVE YOU THE DETAILS ON WHAT CLOTHING IS AVAILABLE TO CHAPTER MEMBERS AND THE PRICES. SHOW YOUR CHAPTER COLORS, PURCHASE CHAPTER CLOTHING.

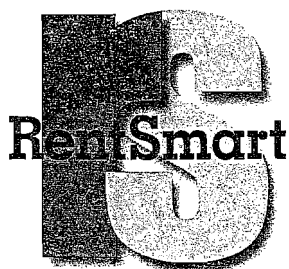

(231) 834-Rent

(231) 225-2296 Cell
(231) 834-5002 Fax
131*550407*19 DC

Pat Gardner,
Owner

**Equipment Rentals
and Sales**

316 South Maple (M-37) • Grant, Michigan 49327

2009

YEARLY CHAPTER FISH CONTEST

BIG LAKE

STEELHEAD - NO ENTRY

BROWN TROUT - NO ENTRY

LAKE TROUT - NO ENTRY

COHO - NO ENTRY

CHINOOK - NO ENTRY

WALLEYE - NO ENTRY

RIVER

STEELHEAD - NO ENTRY

BROWN TROUT - NO ENTRY

LAKE TROUT - NO ENTRY

COHO - NO ENTRY

CHINOOK - NO ENTRY

WALLEYE - BOB ANTZAK 04-01

TO ENTER THE 2009 CONTEST CONTACT BOB ANTZAK AT 616-895-6874. THE ENTRY FEE IS \$5.00 FOR BOTH DIVISIONS AND INCLUDES THE ENTIRE FAMILY. SEND YOUR ENTRIES TO BOB AT 10377 WHITEWOOD DR. WEST OLIVE, MI. 49460. REMEMBER TO ENTER EVERY FISH YOU CATCH, IT MAY BE A BIG WINNER.

HIT-MAN CHARTER SERVICE

SPORT FISHING
LAKE MICHIGAN AT GRAND HAVEN

CAPT. CHIP KLEIN

P.O. BOX 709
GRAND HAVEN, MI 49417

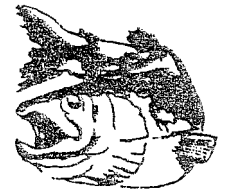

Home (616) 677-1860
Boat (616) 638-7226

www.hitmanfishingcharters.com

**Evinrude
Johnson.**

YAMAHA

Vans Sport Center, Inc.

1855 Alpine Ave., N.W.
Grand Rapids, Michigan 49504

Ph. (616) 364-0666
www.vanssports.com

**FACTORY AUTHORIZED SALES & SERVICE
WE SERVICE ALL MAKES**

Husqvarna

**SUZUKI
MARINE**

NOTICE

THE COMPANIES THAT PARTICIPATE WITH OUR "IT PAY'S TO BELONG PROGRAM WILL NOW BE LISTED IN THE STATE NEWSPAPER, "THE GREAT LAKES SPORT FISHING NEWS". THIS IS DUE TO THE LENGTH OF COMPANIES THAT PARTICIPATE IN THE PROGRAM.

SICK BAY

IF YOU KNOW OF ANY MEMBERS THAT ARE IN SICK BAY, OR HAVE PASSED AWAY, PLEASE CONTACT DAVE NOWICKI AT 616-532-7727. THE FOLLOWING MEMBERS ARE IN SICK BAY JIM FRIELINK, EGON KETTING.

Boat Dockage
Launching &
Storage

**INSTA LAUNCH
CAMPGROUND**



& MARINA

Cabin & Trailer Rental
Boat, Pontoon, Canoe,
Kayak Rental



INSTA LAUNCH CAMPGROUND & MARINA, LLC

20 Park Avenue • Manistee, MI 49660
231-723-3901 • Toll Free 1-866-452-8642
Your Hosts: Jim & Debbie Baldwin
Visit us on the Web at www.insta-launch.com



BEST PRICES GUARANTEED!

fish

Remarkable aquatic animal typically weighing less than 10 pounds which, without gear, tackle, or equipment of any kind and using nothing more than hypnotic suggestion, can easily lure an angler as much as 50 times its size tens or even hundreds of miles into inhospitable terrain or unfamiliar waters and keep him there for hours with nothing more than a couple of false rises and a few practiced flicks of its tail.

MEMBERS CLASSIFIED

ALL CURRENT MEMBERS MAY ADVERTISE IN THIS NEWSLETTER IN THE FORM OF CLASSIFIED ADS FOR PERSONAL PROPERTY AT NO COST. THIS DOES NOT APPLY TO MEMBERS WHO OWN BUSINESSES AND WISH TO ADVERTISE PRODUCTS AVAILABLE THROUGH THE BUSINESS. THE AD WILL RUN FOR 6 MONTHS. PLEASE CONTACT THE EDITOR IF THE ITEM IS SOLD BEFORE 6 MONTHS.

FOR SALE: X98 LOWRANCE FISH FINDER. DUAL BEAM TRANSDUCER, 50 AND 200 KZ SPEED AND TEMP. 3 YEARS OLD. \$100.00 JERRY 616-696-9141 OR badesbiker@wmis.net

FOR SALE: 1986 SEA SPRITE 19.5 FT. FIBERGLASS BOAT WITH NEWER GALVANIZED TRAILER. BOAT HAS CUDDY CABIN THAT SLEEPS TWO. CHEVY FOUR-CYLINDER 110 HP INBOARD WITH ALPHA-ONE OUT DRIVE. BIMINI TOP AND COVER INCLUDED. ENGINE NEEDS OVERHAUL, INTERIOR NEEDS SOME TLC, WOULD MAKE A GREAT FISHING BOAT. \$950.00 JON 616-450-7082

FOR SALE: BROWNING FISHING ROD, MIDAS SPINNING ROD-NOODLE LIGHT SERIES 10'-6" LG. 35 MILLION BORON/GRAPHITE MATRIX BLANK, FUGI ALUMINUM OXIDE GUIDES, GRAPHITE EXPOSED-BLANK REEL SEAT, PREMIUM CORK HANDLE, W/ZEBCO QUANTUM SPIN REEL. \$50.00 FOR COMBO DAVE 616-453-5513 12/08

CRIMPING POINTERS

Here's how to make a crimp correctly. The procedure works with one sleeve or two:



1. Put the end of the wire through the sleeve and then through the eye.



2. Bring the end back through the sleeve. There shouldn't be any excess sticking through.

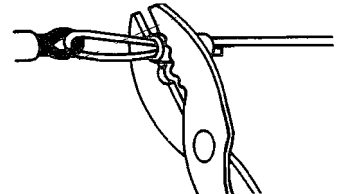

3. Using a crimping tool and matching the correct slot on the tool to the sleeve, crimp down as hard as you can near the bottom end of the sleeve. Then move up near the top of the sleeve and crimp it at a 90-degree angle to the first crimp.

ATTENTION

CHECK THE FIRST LINE OF YOUR ADDRESS LABEL ON THIS NEWSLETTER. IF IT IS DATED BEFORE THIS MONTH AND YEAR, YOUR MEMBERSHIP HAS EXPIRED. IF YOUR MEMBERSHIP HAS EXPIRED, YOU ARE NO LONGER AN ACTIVE MEMBER, AND CANNOT PARTICIPATE IN CHAPTER EVENTS THAT REQUIRE ACTIVE MEMBERSHIP.

SPRING GRAND RAPIDS CHAPTER RIVER RULES

1. DATE: SATURDAY MARCH 28, 2009
2. OPEN TO ENTIRE GRAND, ROGUE, MUSKEGON RIVERS ONLY.
3. PAID TO DATE MEMBERS ONLY.
4. STARTING TIME 6:00 AM, FINISH AT 2:00 PM SHARP.
5. WEIGH-IN NO LATER THAN 3:00 PM SHARP.
6. ENTRY FEE, \$5.00 (NON-REFUNDABLE).
7. PRE-REGISTRATION REQUIRED BY THURSDAY MARCH 26, 2009 9:00 P.M.
8. CONTACT BILL NEWELL 616-897-6949 OR BOB STREK 616-453-3109.
9. CATCH MUST BE STEELHEAD.
10. THREE (3) FISH LIMIT.
11. ALL FISH MUST BE 20" OR OVER.
12. ALL FISH MUST BE LEGALLY CAUGHT.
13. TWO RODS PER PERSON, STATE RULES APPLY.
14. ALL FISH ENTERED WILL BE JUDGED BY WEIGHT ONLY.
15. WEIGH-IN SITE TO BE SELECTED BY CONTEST CHAIRMAN. EAST SIDE SIXTH STREET PARK.
16. TROPHIES FOR FIRST AND SECOND PLACE, IN CASE OF TIE, TWO TROPHIES WILL BE AWARDED. \$20.00 CASH AWARD FOR LARGEST FISH. ONE REVOLVING TROPHY FOR FIRST PLACE.

NOTE: ALL CONTROVERSIES, PROBLEMS, ETC. ARISING WITH ABOVE CONTEST WILL BE RESOLVED BY THE STEELHEAD CHAPTER BOARD AT A SCHEDULED BOARD MEETING, NOT AT AN OPEN MEMBERSHIP MEETING.

GRAND RAPIDS STEELHEADERS 2009 CALENDAR OF EVENTS

MARCH	19-22 SPORT, FISHING, AND RV SHOW - DEVOS PLACE 19-22 SPORT, FISHING AND RV SHOW FISHING CONTEST 28 SPRING RIVER CONTEST 6:00 A.M. GRAND, ROGUE, MUSKEGON RIVERS 30 MEMBERSHIP MEETING 7:30 PM/SOCIAL HOUR 6:30 PM - DIAMOND HALL
APRIL	6 BOARD OF DIRECTORS MEETING 7:30 PM DIAMOND HALL 20 REGION II MEETING 7:00 PM AT SOUTH HAVEN 27 MEMBERSHIP MEETING 7:30 PM/SOCIAL HOUR 6:30 PM - DIAMOND HALL
MAY	4 BOARD OF DIRECTORS MEETING 7:30 PM DIAMOND HALL 16 CHAPTER BIG LAKE CONTEST - GRAND HAVEN 6:00 AM 18 MEMBERSHIP MEETING 7:30 PM/SOCIAL HOUR 6:30 PM - DIAMOND HALL
JUNE	1 BOARD OF DIRECTORS MEETING 7:30 PM DIAMOND HALL 19-21 CHAPTER WALLEYE OUTING 29 MEMBERSHIP MEETING 7:30 PM/SOCIAL HOUR 6:30 PM - DIAMOND HALL

ICE OUTING - LONG LAKE, SPARTA, MI

February 7, 2009

This was not a typical ice fishing outing of recent years. Instead of blistering cold & windy conditions, it was mild. Some wind in the early morning made for some interesting one-sided conversation from people trying to set up their shanties. Temps were 45 - 50. A very rare and mild day for a long cold winter! Fishing was slow, but always more fun than working. There was plenty of chili, rolls and beverages.

1st place went to Chris Edwards with 2 bluegills - the largest was 7 15/16 For \$40 first prize.

2nd place went to Al Davis, also with 2 bluegills - his largest was 7 7/8 for \$20 prize

3rd place went to Kris Guiles with 11 bluegill - the largest was 6 1/2 (most were 4 -5")

Thanks to all that came and participated. All in all a very pleasant day - even for ice fishing!
Capt. Kris Guiles

HOW TO BUILD THE DOUBLE PLANKER BOARD

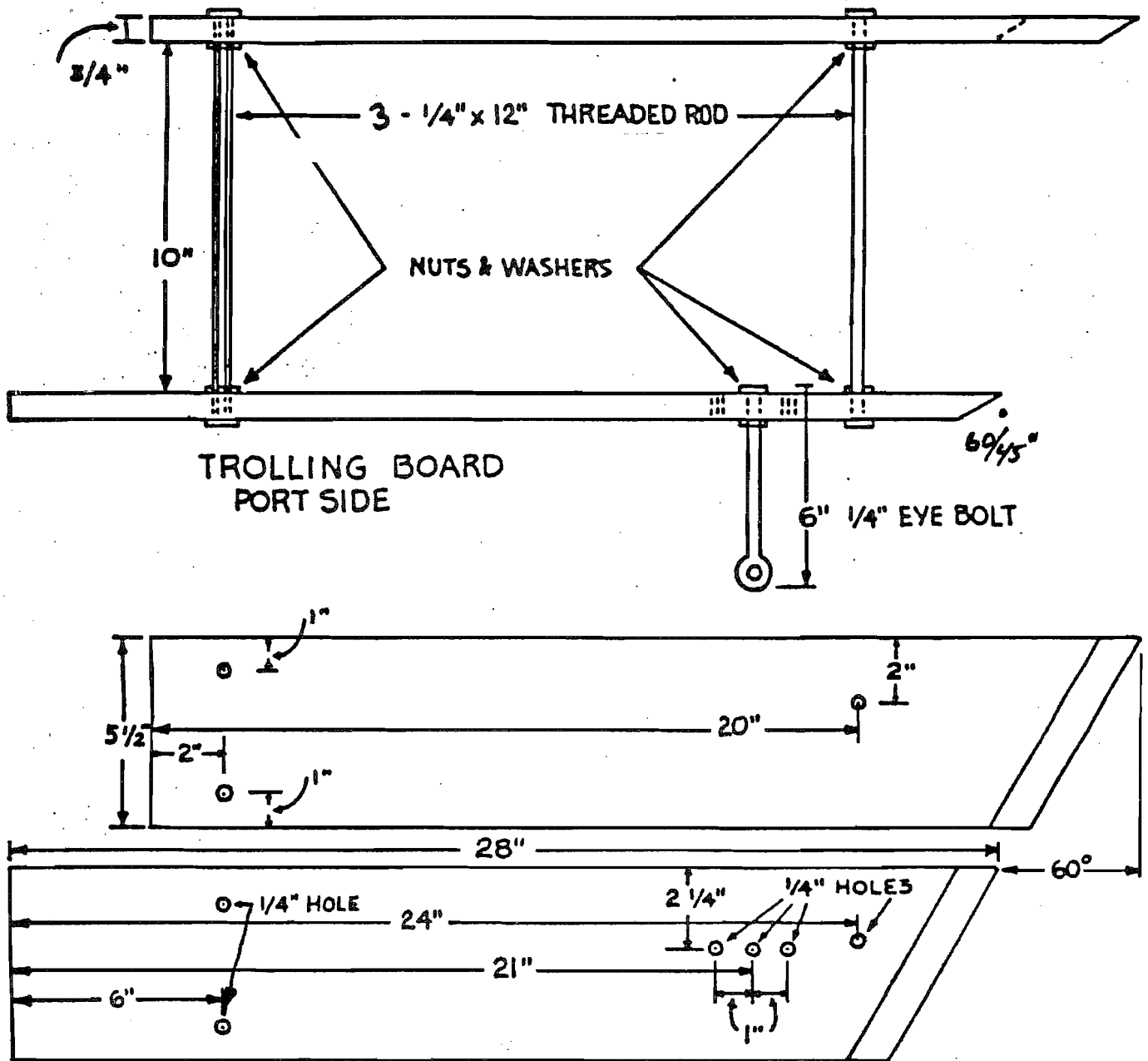

MATERIALS FOR BOTH PORT AND STARBOARD PLANKERS

- 1 pcs 1" X 6" X 8' REDWOOD (CUT AS SHOWN)
- 6 pcs 12" X 1/4" THREADED ROD
- 2 pcs 1/4" X 6" EYE BOLT
- 28 pcs 1/4" WASHERS
- 28 pcs 1/4" NUTS
- HIGLY VISIBLE PAINT AND ~~OR~~ FLAGS OR FOAM MAST
- 100' OF TETHER LINE FOR EACH SIDE (80LB TEST MONOFILAMENT
OR
200 LB TEST SMALL DIA NYLON)

REMEMBER TO REVERSE THE PATTERN FOR THE STARBOARD PLANKER



From the Galley...

SALMON-COHO-STEELHEAD-TROUT RECIPES

Fillet all fish, remove skin, remove mud line (dark line on outside of fillet) .

GRILLED FISH

Fish Fillets, olive oil, paprika, garlic salt, other spices as desired.

Cut fish into large fillets (5 X 5 inch). Sprinkle both sides of fillet with paprika, garlic salt, any other spices as desired. Brush olive oil over fillets. Heat grill to maximum heat. Brush olive oil on grill grates. Put fillets directly on grates. Grill about 5 minutes and turn over. Grill 5 minutes on other side or until fillet flakes. Remove from grill. Serve with melted margarine over the top as a coating.

FISH FRY

Mix the following in a bowl. 3/4 bottle beer (your own brand), 2 eggs, cover with garlic salt or powder, dash of salt and pepper, 1/3 tsp. sugar, 3/4 tsp. Lawreys seasoning salt, Mix mess together.

Use large frying pan. Fill pan 5/8 full with veg. oil and heat to 350 degree. Slice potatoes 1/4 inch thick. Put potatoes in hot oil and fry for 5 minutes. Dip fish fillets into batter and flour. Put fish in with potatoes and fry until golden brown. Drain and serve.

FISH BOIL

You will need the following for the boil. 2-3 lbs fish fillets, 3 lbs small potatoes (1-3 inch size), 2 lbs small onions, kosher salt. It is recommended that you use a trout kettle to cook this in. (Trout kettles are available from most larger sport shops.)

Fill 12 quart trout kettle 3/4 full with water. Heat water to a rolling boil, then add 1 cup kosher salt, add potatoes. Let boil 12 to 15 minutes. Add onions. Boil 6 minutes. Put fish in trout kettle basket. Add 1 cup kosher salt to water. Put fish basket in kettle. Let boil 12-15 minutes. Drain. Serve with melted butter.

Tip--Keep the water at a rolling boil. If it is not rolling, wait until it rolls to begin timing. Time from rolling boil.

SAVE THE DATE

REGIONAL FISHERY WORKSHOPS

The Michigan Sea Grant College Program and Michigan State University Extension, in partnership with the Department of Natural Resources Fisheries Division and other fishery organizations, will again be hosting six public information workshops offering current research and information related to the status of the Great Lakes fishery. Workshops are open to the public, and will provide valuable information for anglers, charter captains, resource professionals, and others interested in attending.

When and Where?

Full day Michigan Regional Fishery Workshops will be hosted at:

January 16 - Ludington Regional
Fishery Workshop
Ramada Inn, 4679 West U.S. 10
Ludington, MI 49431

February 21 - St. Joseph
Regional Fishery Workshop
Berrien County MSUE Office
(tentative location) 1737 Hillandale
Rd., Benton Harbor, MI 49022

April 4 - Bad Axe Lake Huron
Regional Fishery Workshop
The Franklin Inn, 1070 E. Huron Ave.
(M-102), Bad Axe, MI

April 18 - Alpena Lake Huron
Regional Fishery Workshop
P.O. Meeting Hall (National Order
of the Eagles), 1480 M-32 West
Alpena, MI

April 25 - Grand Haven Regional
Fishery Workshop
The American Legion, Charles
Corkin Post # 28, 700 Harbor Ave.,
Grand Haven, MI 49417

May 2 - Straits Area Regional
Fishery Workshop
Location TBD, St. Ignace

WINTER / SPRING 2009

Registration fees

Fees for individual workshops vary from \$15 to \$25 based on location, lunch costs, etc. Call or email for details and costs related to individual workshops.

Lake Huron Contact:

Brandon Schroeder
(989) 984-1056
schroe45@msu.edu

Lake Michigan Contact:

Dan O'Keefe
(616) 994-4544
okeyeed@msu.edu

Additional workshop details, as they are available, will be posted online:

www.miseagrant.umich.edu/fisheries



MICHIGAN STATE
UNIVERSITY
EXTENSION

MSU is an affirmative-action, equal opportunity institution. Michigan State University Extension programs and materials are open to all without regard to race, color, national origin, gender, religion, age, disability, political beliefs, sexual orientation, marital status, or family status. Reasonable accommodations made for persons with disabilities with advanced notice.

MICHIGAN STEELHEAD & SALMON
FISHERMEN'S ASSOCIATION - GR
P.O. BOX 1474
GRAND RAPIDS, MI. 49501

NONPROFIT ORGANIZATION
U.S. POSTAGE
GRAND RAPIDS, MI
PERMIT NO. 829

The Birds Nest

Outfitters
Since 1981

www.fliesandtackle.com

Live Bait

Freshwater Flies from 25 cents

Custom Big Lake Flies

Taxidermy

Fly Tying Classes

Guide Services

Certified Scale for Weighing Fish

15% off Everything in the Store For Steelheaders

Weekly Fishing Contest

We Match Competitors Prices

738 Bridge St., NW, Grand Rapids Formally 'Johnny's Sport Shop' 616-458-0922